

# Installation Guide

F22

Calculator for heating or cooling applications

## Calculator F22 installation guide

For more detailed information, see F22 manual

### Delivery

The calculator is normally delivered in transport mode. In this mode only the system clock is active and no measurements are done. Transport mode is indicated by "no" in the upper left corner of the display. Prior to the installation the calculator must be activated, by pressing the "Push-button" in approximately 5 seconds the meter will normally go in to "INIT"-mode. In "INIT"-mode one can set the meter, see manual for further instructions. When exiting the "INIT"-mode the meter will enter "normal mode" (operating mode), the display will indicate "10" in the upper left corner.

### Circuit board

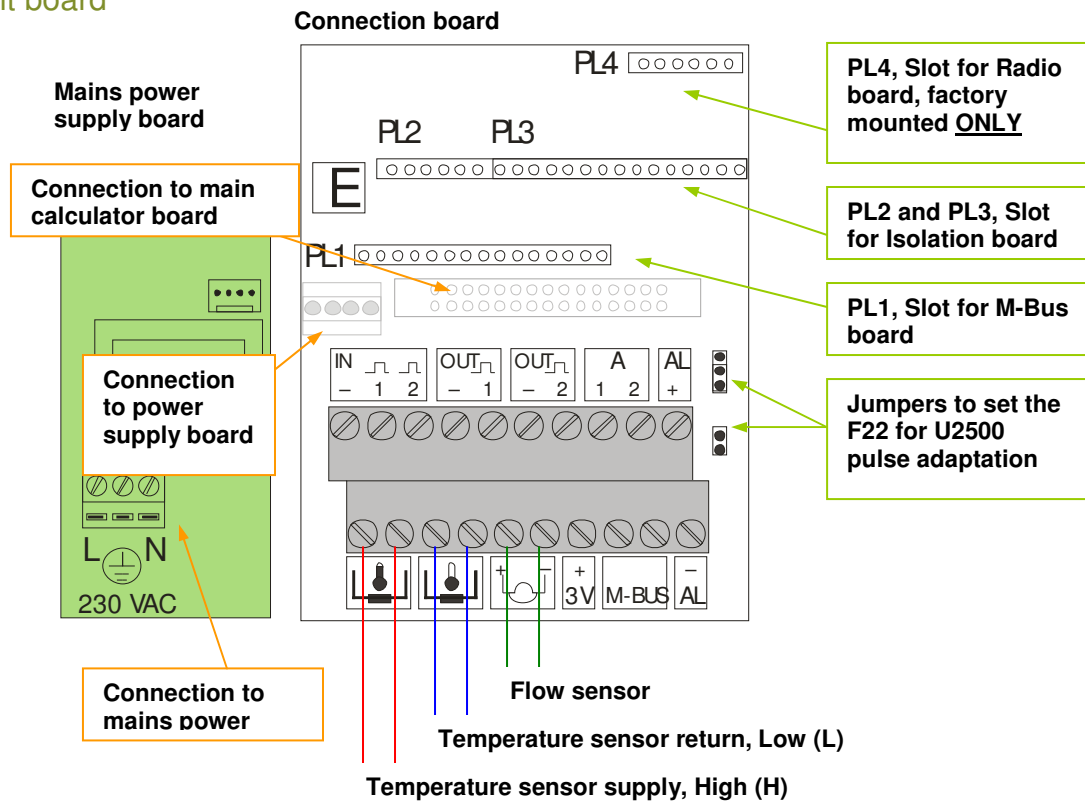

### Connection according to EN1434

No*	Signal description according EN1434
5	High temperature sensor
6	High temperature sensor
7	Low temperature sensor
8	Low temperature sensor
10	Flow sensor signal input (+)
11	Flow sensor signal input (-)
16	Pulse 1 output (+)
17	Pulse 1 output (-)
18	Pulse 2 output (+)
19	Pulse 2 output (-)
24	M-Bus interface**
25	M-Bus interface**

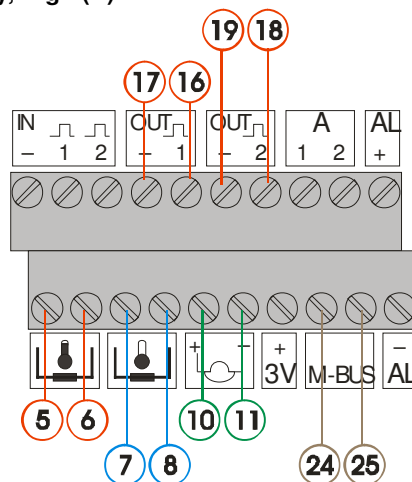

## U2500 Flow sensor connection

### Jumper setting U2500

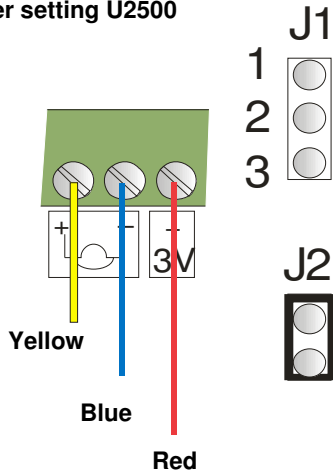

### Jumper setting normal flow sensor

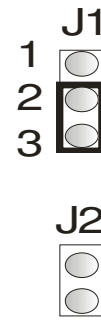

## Pulse outputs

- Pulse output 1, energy (display sequence 10)
- Pulse output 2, volume (display sequence 11)
- 

The last digit and the unit will show the pulse weight of the pulse output. One increment of the last digit in the display will result in one pulse emitted on the pulse output.

*Example:* Display sequence “10”, energy, pulse output 1. The unit is [MWh] and the display shows “0.25”. The pulse weight of the pulse output is then 0.01 [MWh]. Every pulse emitted will be 0.01 [MWh] (10 [kWh]).

Voltage range	[V]	3 – 30
Maximum current	[mA]	20
Pulse duration	[ms]	250

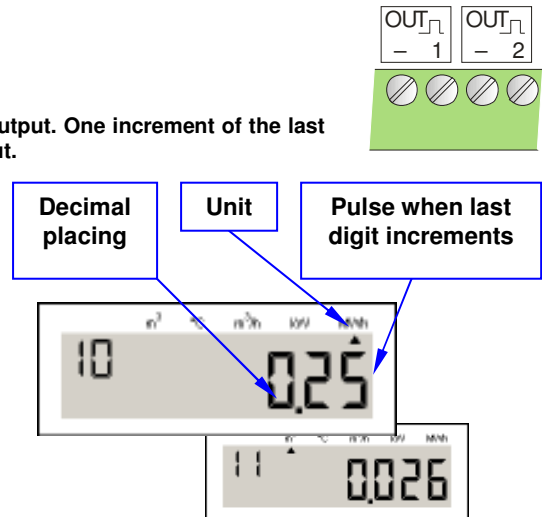

## Pulse inputs

The calculator has two pulse inputs and two pulse input registers. Pulses registered on the pulse input are accumulated to the corresponding pulse register.

Maximum voltage	[V]	3
Maximum current	[ $\mu$ A]	4
Maximum frequency	[Hz]	12
Minimum pulse length (contact closure)	[ms]	40

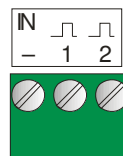

## M-Bus (OPTION)

The F22 requires an M-Bus board “FCM2-21DM” placed in slot “PL1” in order to communicate with 2-wire M-Bus. The M-Bus output is isolated and polarity insensitive

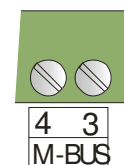

## Setting the calculator into operating mode

The calculator is delivered in “transport mode”, a power save mode where the calculator doesn’t measure or calculate. In order to complete the installation the calculator must be set into “**operation mode**”. The easiest way to enter operation mode is:

1. Hold the display button pressed until the service mode is reached.
2. Hold the display button until service display sequence “A0” is reached.
3. Change the number in display sequence “A0” to 1.
4. Hold the display button until the calculator is set to operation mode.

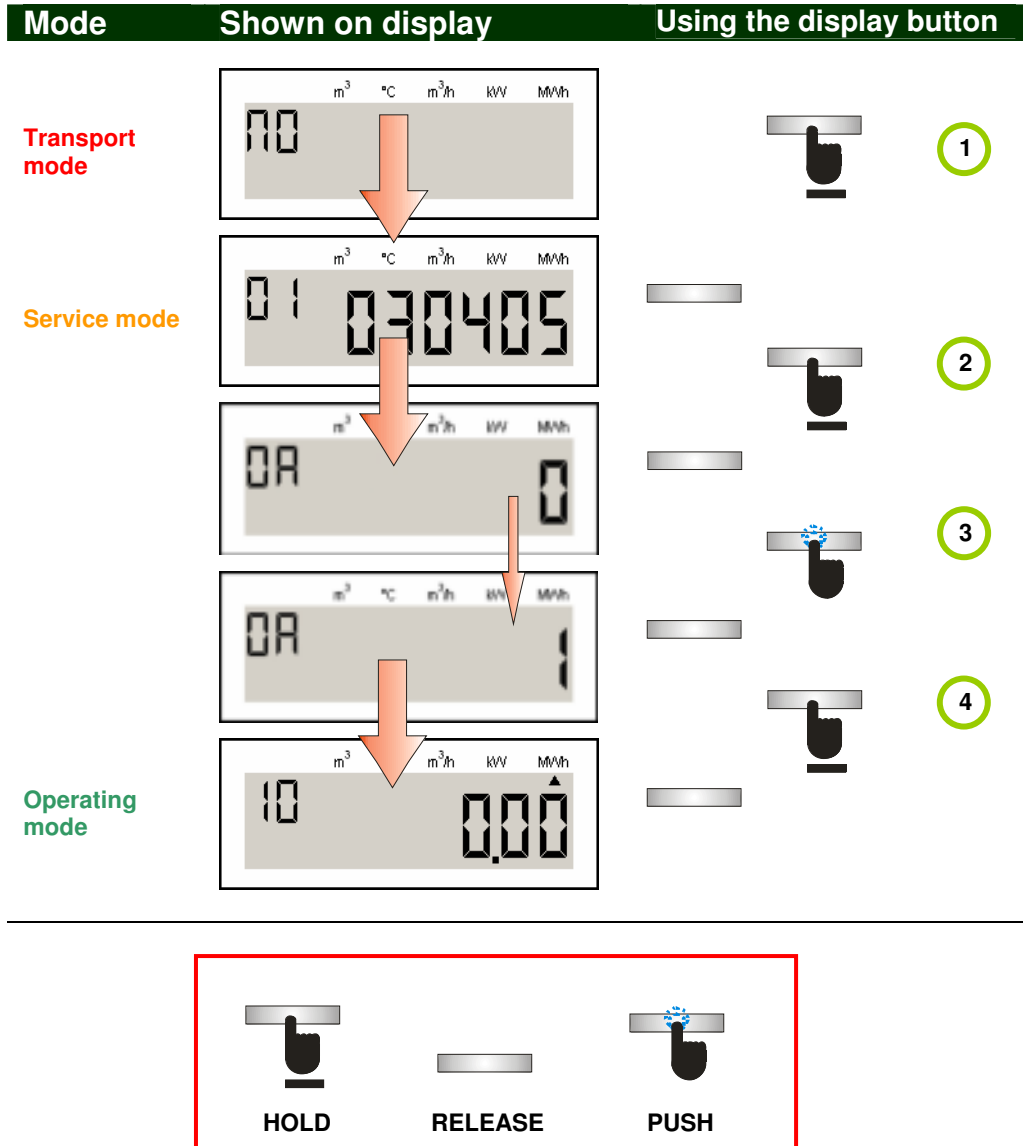
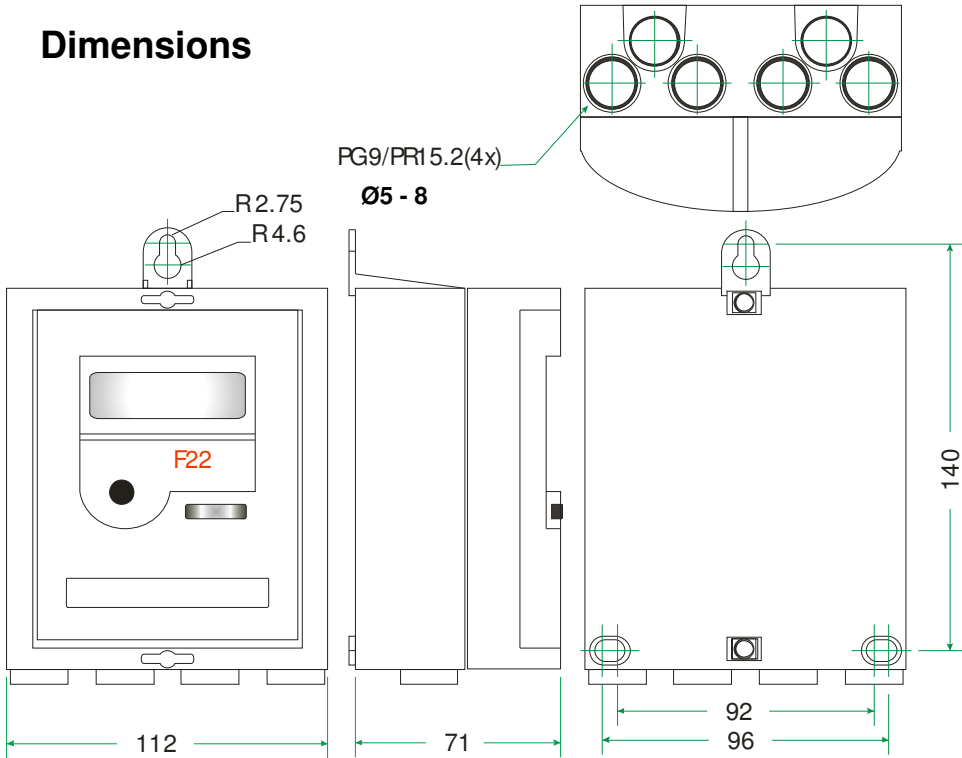
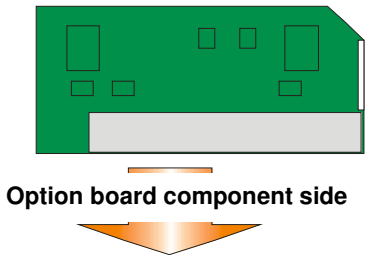

Fig. 2.2, Setting the calculator into operation mode to complete installation

# Dimensions



## Placing option board and seals



Facade side aligned

**Placement of option board:**  
Align right (facade side right)  
ensure all pins are connected,  
component side turned to terminals

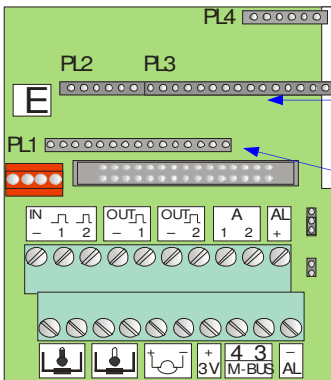
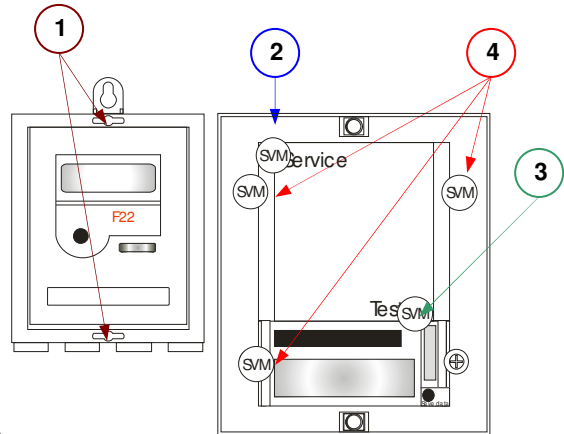

**PL2 / PL3**  
Slot for isolation board  
"FCRC-2"

**PL1**  
Slot for M-Bus board or  
RS232/M-Bus board  
"FCM2-2"

- Seals**
1. Installation seal, installation and tampering protection.
  2. Service seal, to protect the calculator entering service mode.
  3. Test seal, to protect the calculator entering test mode.
  4. Factory seal, protect electronic

**Elster Messtechnik GmbH**  
Otto-Hahn-Str 25  
68623 Lampertheim

[www.elstermesstechnik.com](http://www.elstermesstechnik.com)

F22\_M\_09.22e / 04.10